

## MC 3001 C PDIO

V3.0, 4-Quadrant PWM

with connection of a pulse/direction signal at digital input

### MC 3001 C PD IO

Values at 22°C		MC 3001 C PD IO	DC/BL/LM
Power supply	$U_P$	6 ... 30	V DC
PWM switching frequency	$f_{PWM}$	100	kHz
Efficiency electronic	$\eta$	95	%
Max. continuous output current	$I_{cont}$	1.4	A
Max. peak output current <sup>1)</sup>	$I_{max}$	5	A
Standby current for electronic (@ $U_P = 24V$ )	$I_{el}$	0.06	A
Operating temperature range		-40 ... +85	°C
Mass		75	g

<sup>1)</sup> S2 mode for max. 1s

Interfaces	MC 3001 C PD IO
Configuration from Motion Manager 6.7	USB

### Basic features

- Control of brushless, DC- and linear motors
- Supported sensor systems: incremental encoders (optical or magnetic), Hall sensors (digital or analog)
- Positioning resolution when using analog Hall sensors as position encoder: 4096 increments per revolution
- Pulse/direction input, 1 digital inputs, 2 digital outputs, 2 analog inputs, flexible configuration
- Setpoint specification via USB, quadrature signal, pulse and direction or analog inputs
- Optional stand-alone operation via application programs in all interface versions

### Range of functions

Pulse Input frequency	Up to 500 KHz
Operating modes	PP, PV and homing acc. to IEC 61800-7-201 or IEC 61800-7-301 as well as position-, speed- and torque control via analog setpoint or voltage controller
Speed range for brushless motors with number of pole pairs 1	0 min <sup>-1</sup> ... 30 000 min <sup>-1</sup> with sinusoidal commutation (optionally to 60 000 min <sup>-1</sup> with block commutation)
Application programs	Max. 8 application programs (BASIC), one of which is an autostart function
Additional functions	Touch-probe input, connection of a second incremental encoder, control of a holding brake
Indicator	LEDs for displaying the operating state
Motor types	DC, BL motors and linear motors

**Dimensional drawing (version A - DC Brushed Servomotor)**

Scale reduced mm

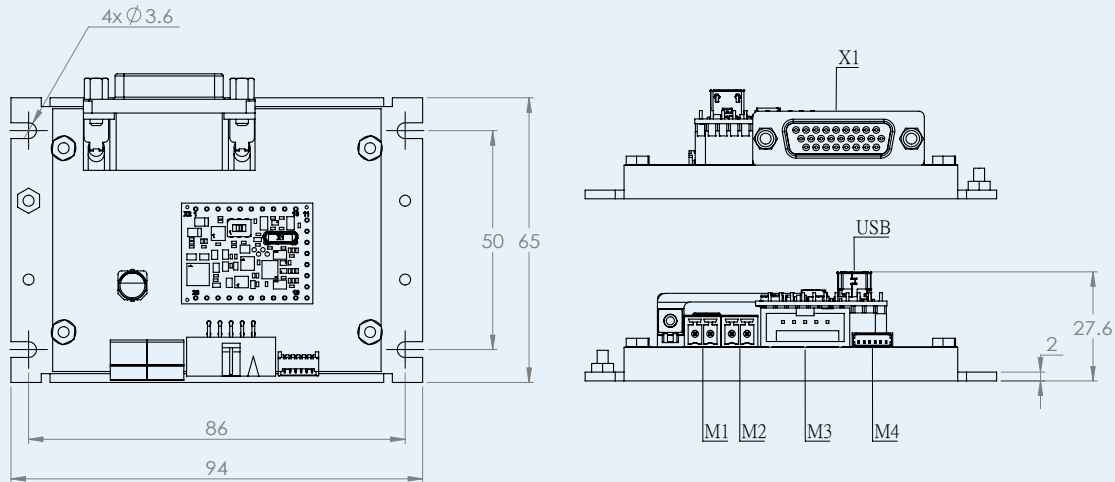

**Connection information**

Designation	Function
M1(U <sub>p</sub> )	Power supply
M2(Motor)	Connection of the motor phases
M3/(M4 Optional)(Encoder)	Connection of an encoder IE2/IEH2/IEH3-L/IE3/IE3-L
USB	Connection of the USB communication
X1(I/O)	Inputs or outputs for external circuits

**Dimensional drawing (version B - DC Brushless Servomotor ) (Linear DC Servomotor-01)**

Scale reduced mm

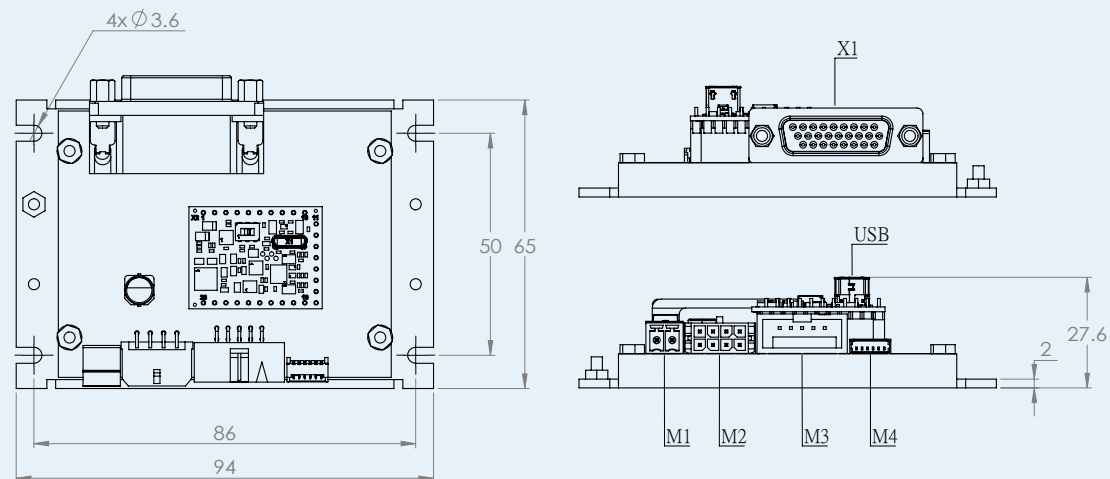

**Connection information**

Designation	Function
M1(U <sub>p</sub> )	Power supply
M2(Motor+Sensor)	Connection of the motor phases and the Hall sensors (3692/K1155/LM-01)
M3/(M4 Optional)(Encoder)	Connection of an encoder IE3/IE3-L/IEF3/IEF3-L/IRS3/IRS3-L/IER3/IER3-L
USB	Connection of the USB communication
X1(I/O)	Inputs or outputs for external circuits